



Inspiring all generations

INSTALLATION INSTRUCTIONS
ARENA MEETING POINT

MPSEATS1-5 (BAR SEAT)

MPSEATP1-5 (POLY SEAT)

BACK PANEL OPTION - MPBACK

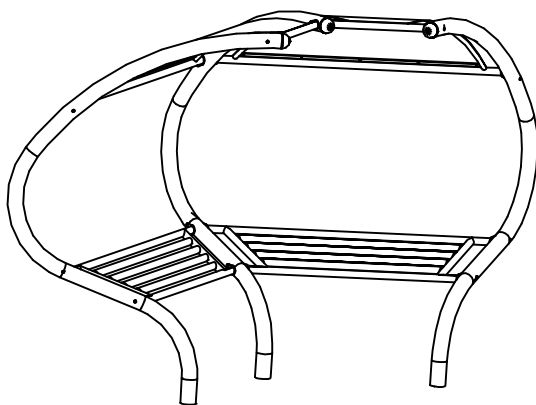



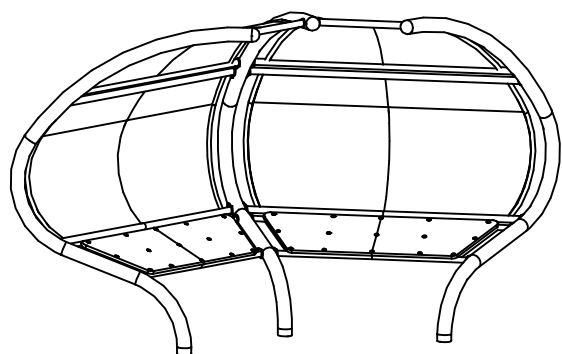

**2 - SEAT ARENA MEETING POINT
MPSEATS2**

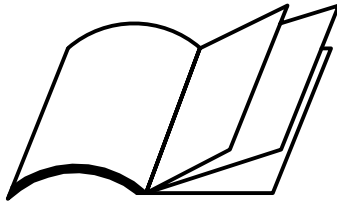

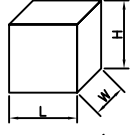
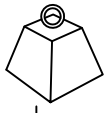
**2 - SEAT ARENA MEETING POINT
MPSEATP2 INCLUDING
BACK PANEL OPTION MPBACK x 2**

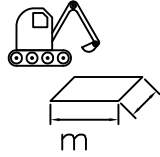

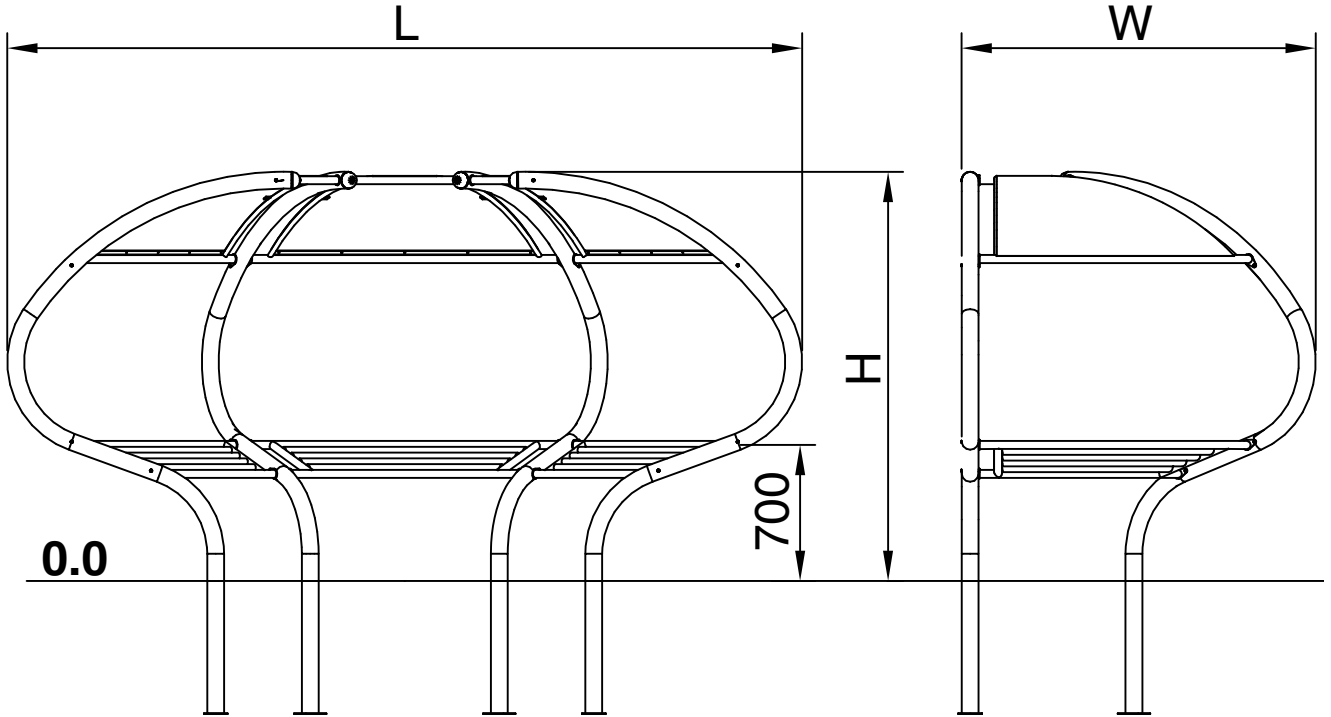

	 LxWxH (m)	 kg	 m ³	 m	 x 2=T
MPSEAT*1	2.15 x 1.36 x 2.16	153.00	1.01	4.0 x 3.0	T=4h
MPSEAT*2	3.65 x 1.85 x 2.16	265.00	1.51	5.5 x 3.5	T=4.5h

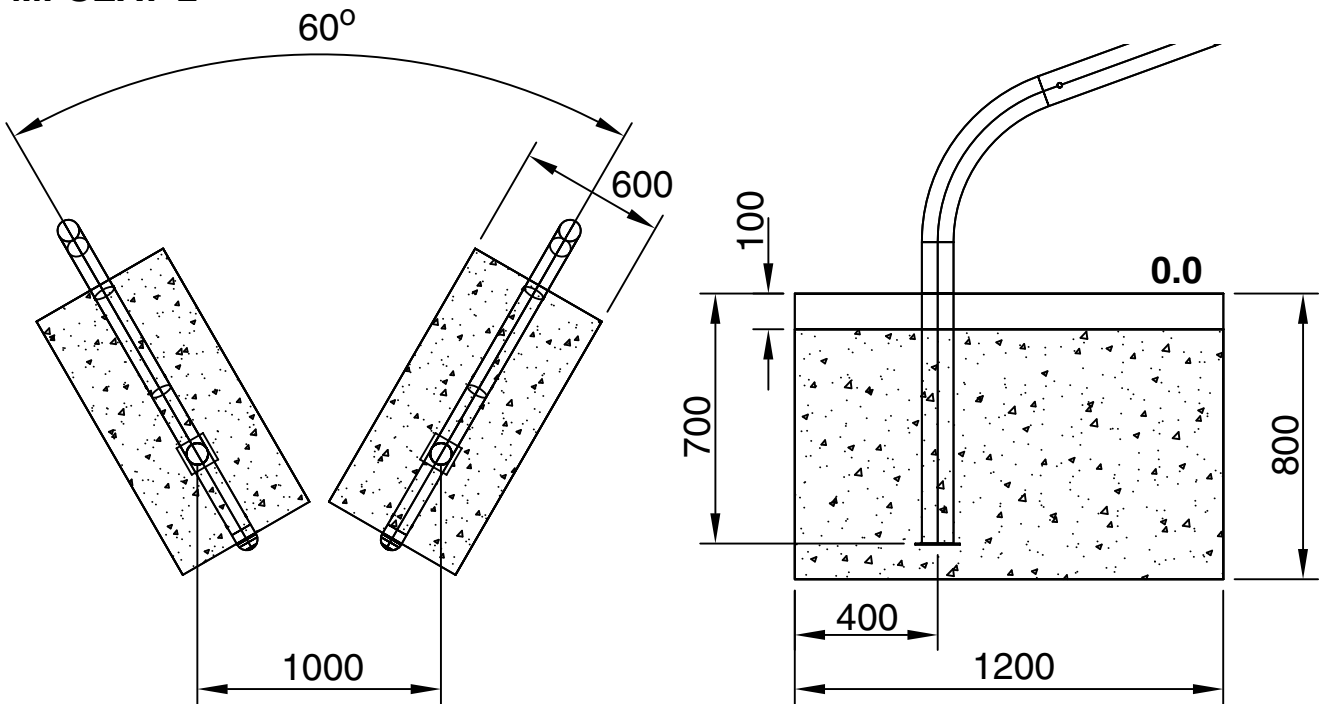

MPSEAT*1
MPSEAT*2

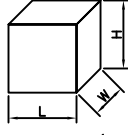
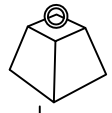
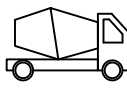
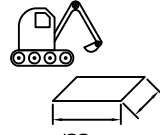

	 LxWxH (m)	 kg	 m ³	 m	 x 3=T
MPSEAT*3	4.20 x 1.87 x 2.16	377.00	1.37	6.0 x 3.5	T=5h
MPSEAT*4	3.65 x 3.18 x 2.16	490.00	1.72	5.5 x 4.5	T=5.5h
MPSEAT*5	4.21 x 3.65 x 2.16	602.00	2.06	6.0 x 5.0	T=6h

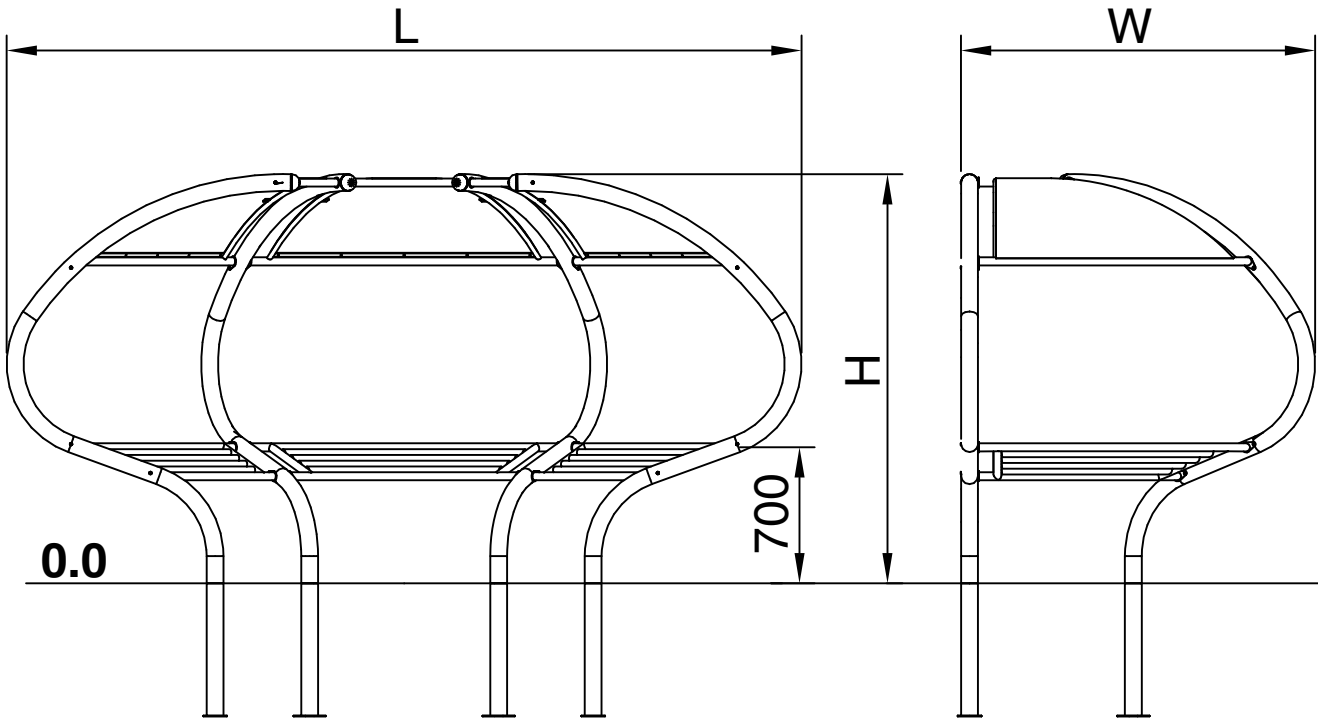

MPSEAT*3
MPSEAT*4
MPSEAT*5

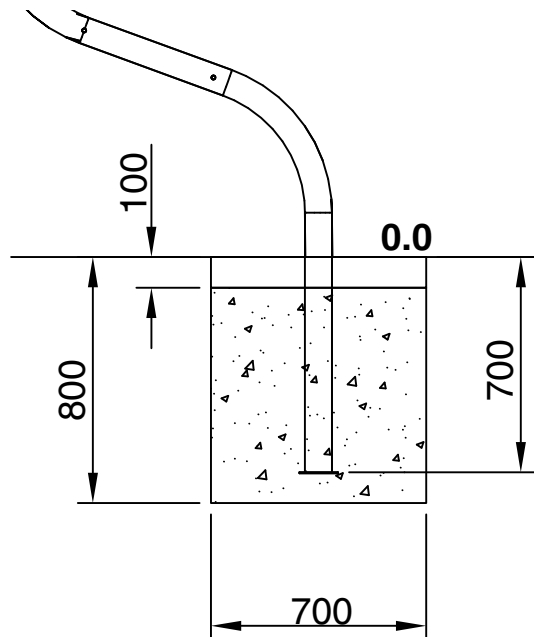
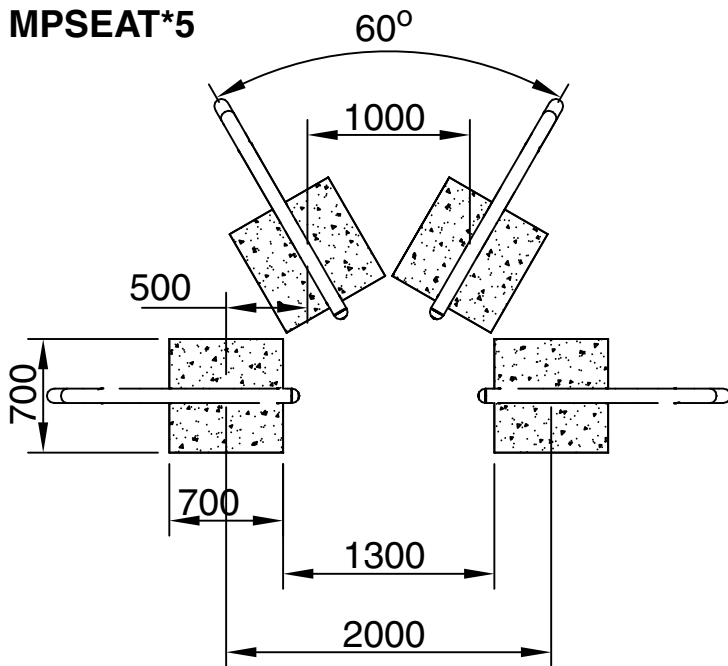

1 PARTS LIST

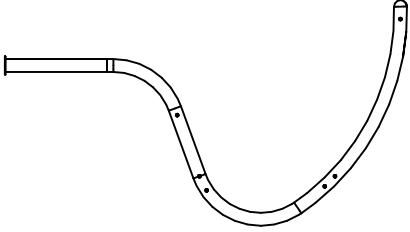
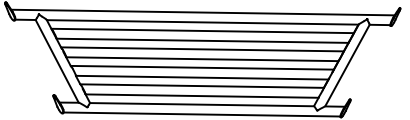
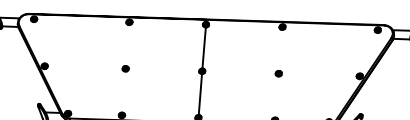
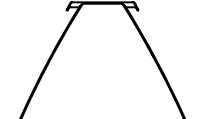
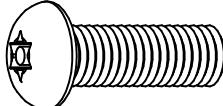
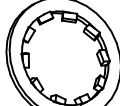
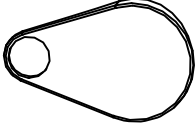
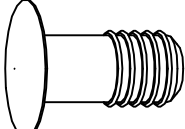
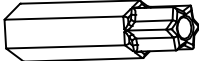
ITEM	REF		QTY										kg
			MPSEATS1	MPSEATP1	MPSEATS2	MPSEATP2	MPSEATS3	MPSEATP3	MPSEATS4	MPSEATP4	MPSEATS5	MPSEATP5	
1.1	26000101		2		3		4		5		6		40.00
1.2	26000501		1		2		3		4		5		25.00
	26000800			1		2		3		4		5	22.00
1.3	26000301		1		2		3		4		5		25.00
1.4	10121030	 M10 X 30	8		16		24		32		40		0.028
1.5	10301000	 M10 12X18X1	8		16		24		32		40		0.002
1.6	19025501		8		16		24		32		40		0.018
1.7	19024501		16		20		24		28		32		0.001
1.8	10121000	 T45 M10					3						0.001

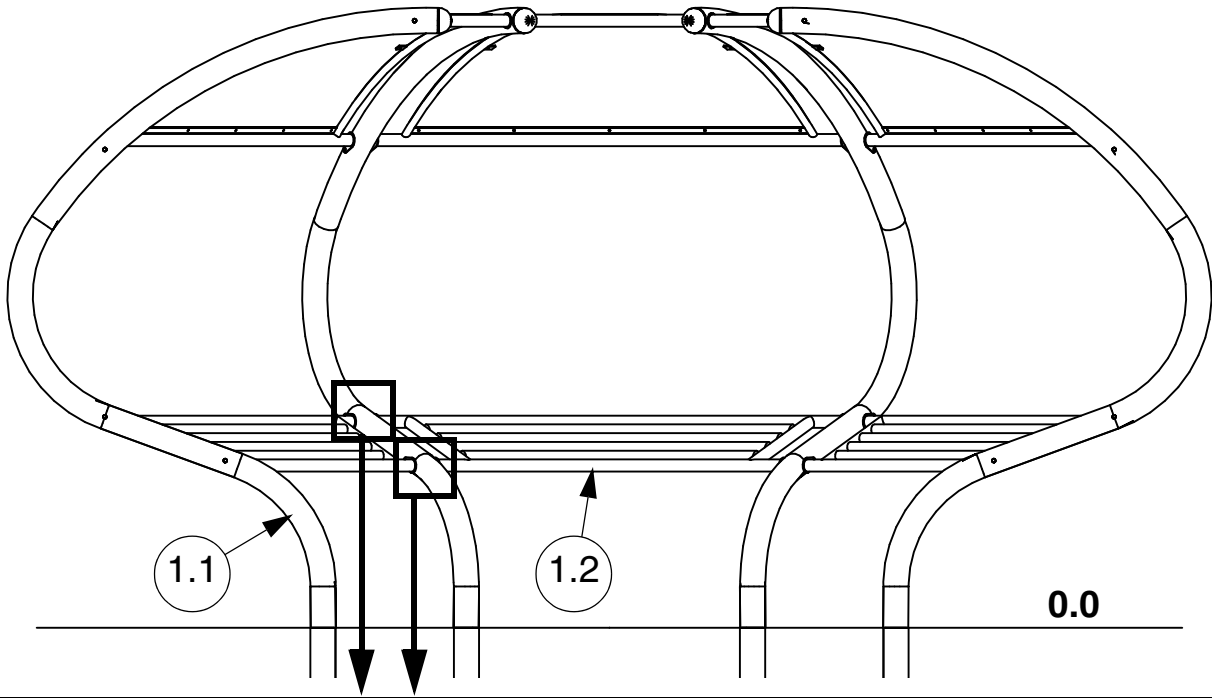

STEP 1

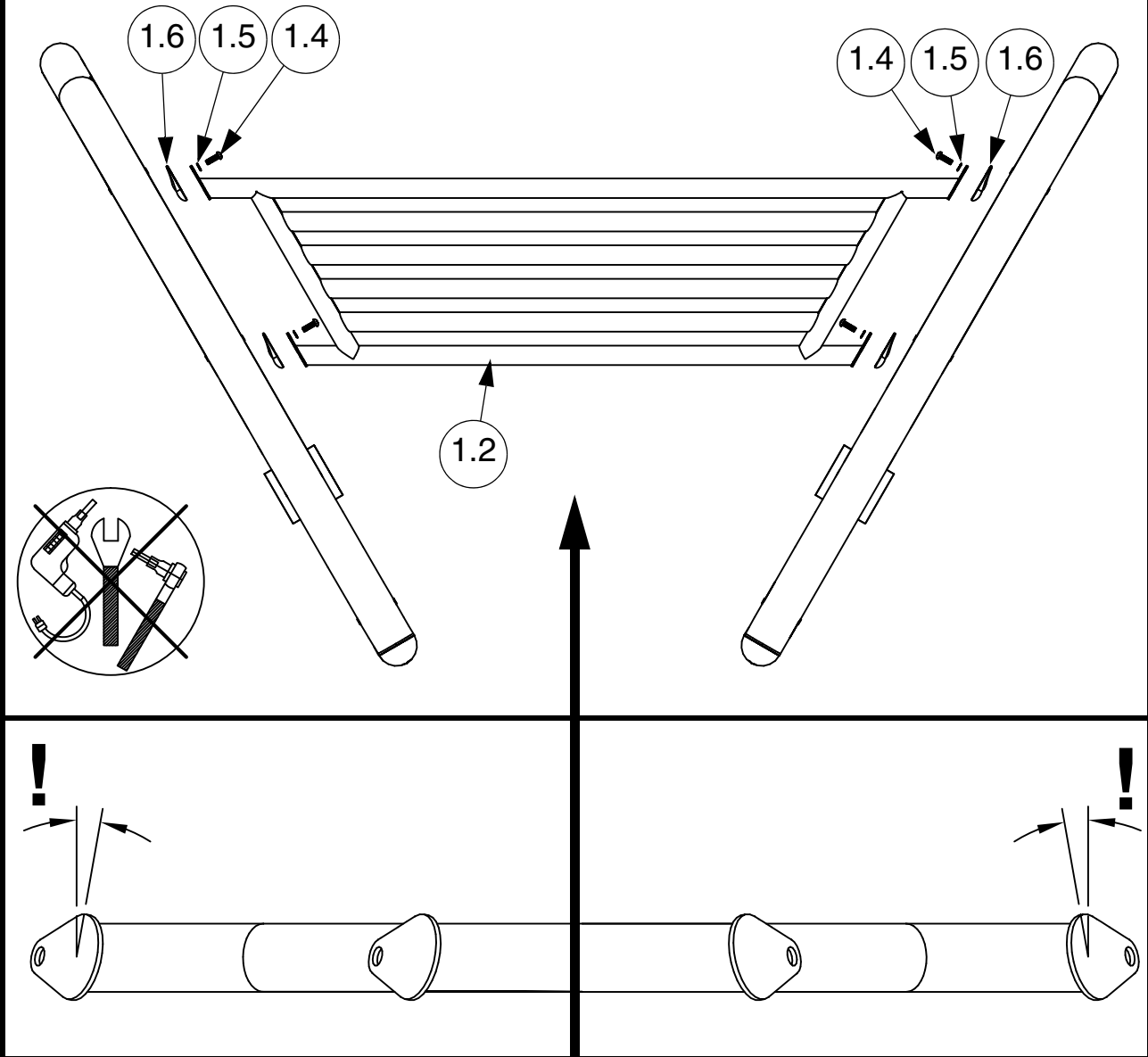

STEP 2

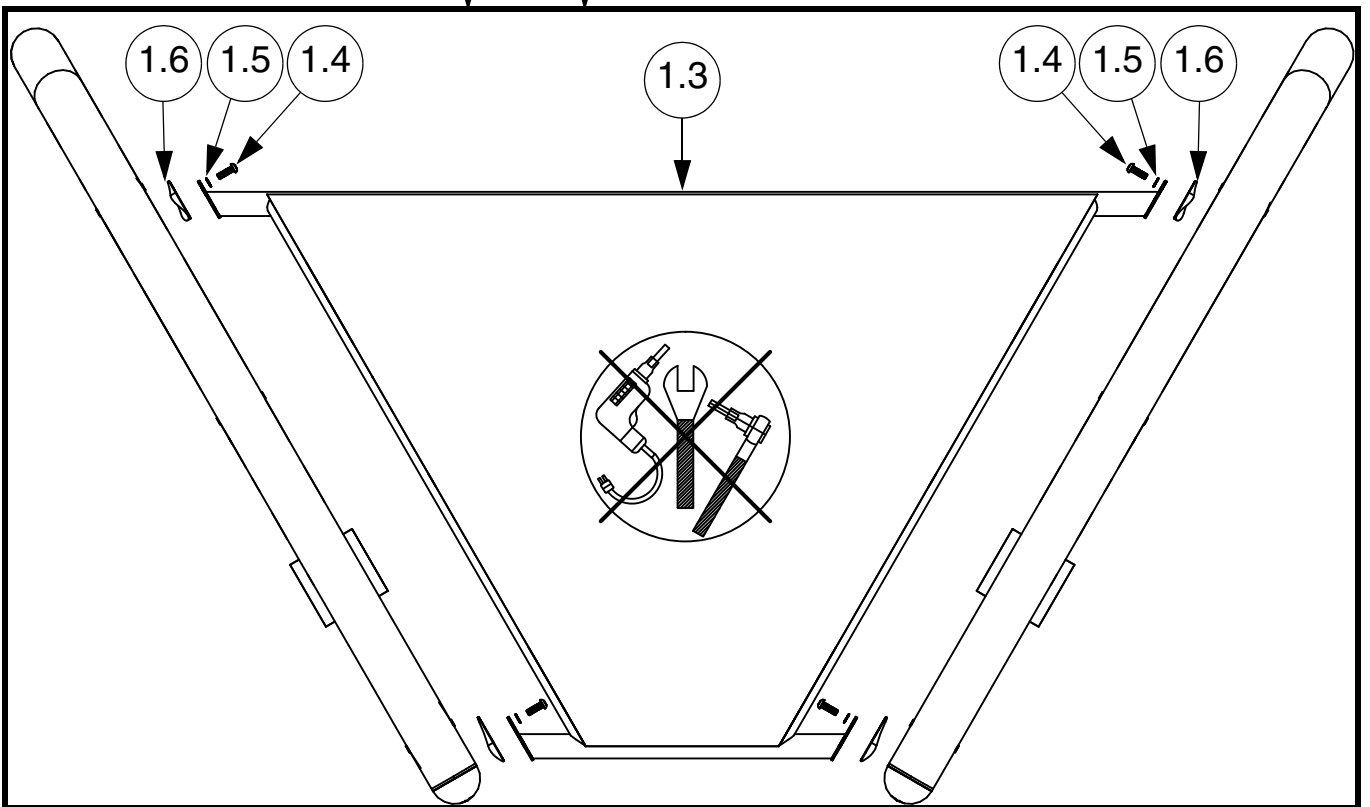
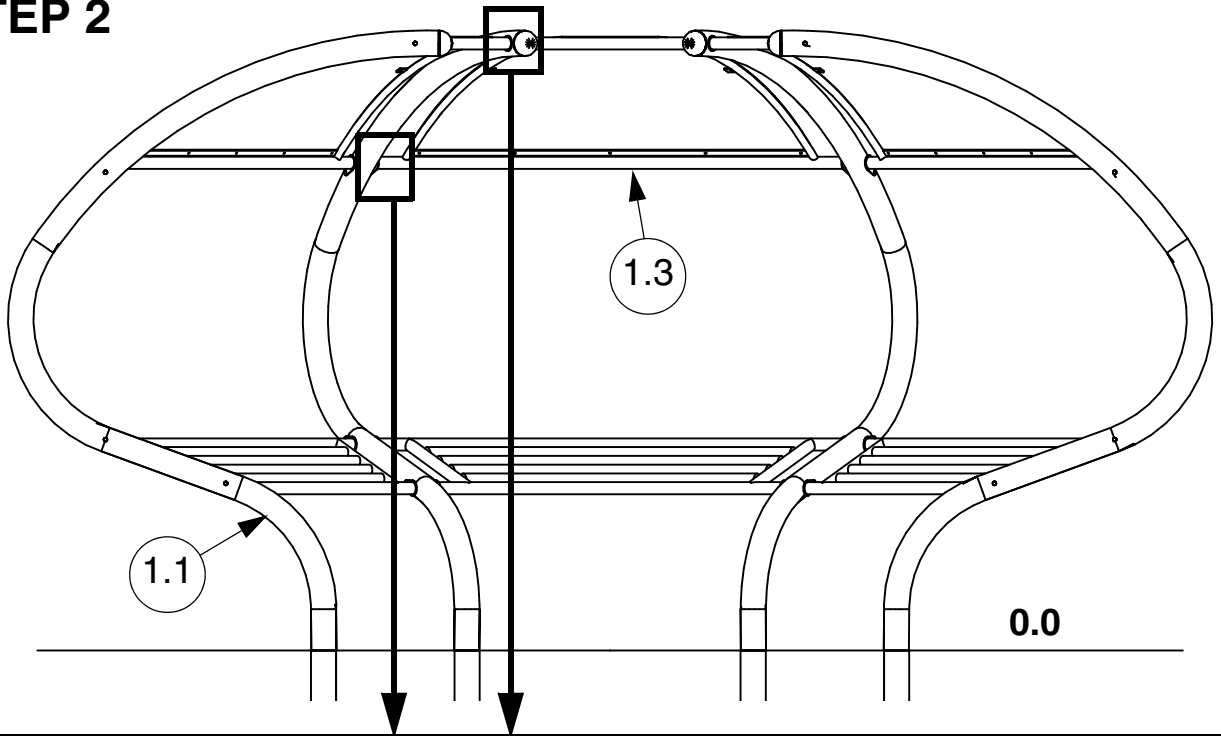

STEP 3

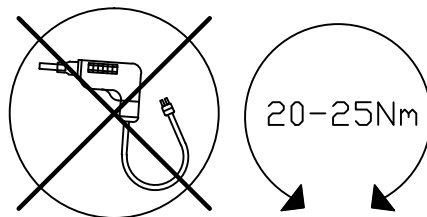

STEP 4

2 MPBACK

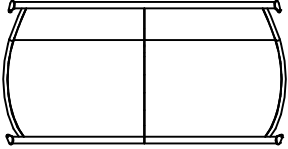
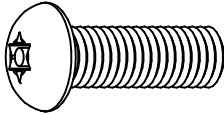
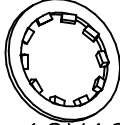
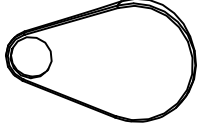
ITEM	REF		QTY										kg
			MPSEATS1	MPSEATP1	MPSEATS2	MPSEATP2	MPSEATS3	MPSEATP3	MPSEATS4	MPSEATP4	MPSEATS5	MPSEATP5	
2.1	26000701		1		2		3		4		5		35.00
2.2	10121030	 M10 X 30	4		8		12		16		20		0.028
2.3	10301000	 M10 12X18X1	4		8		12		16		20		0.002
2.4	19025501		4		8		12		16		20		0.018

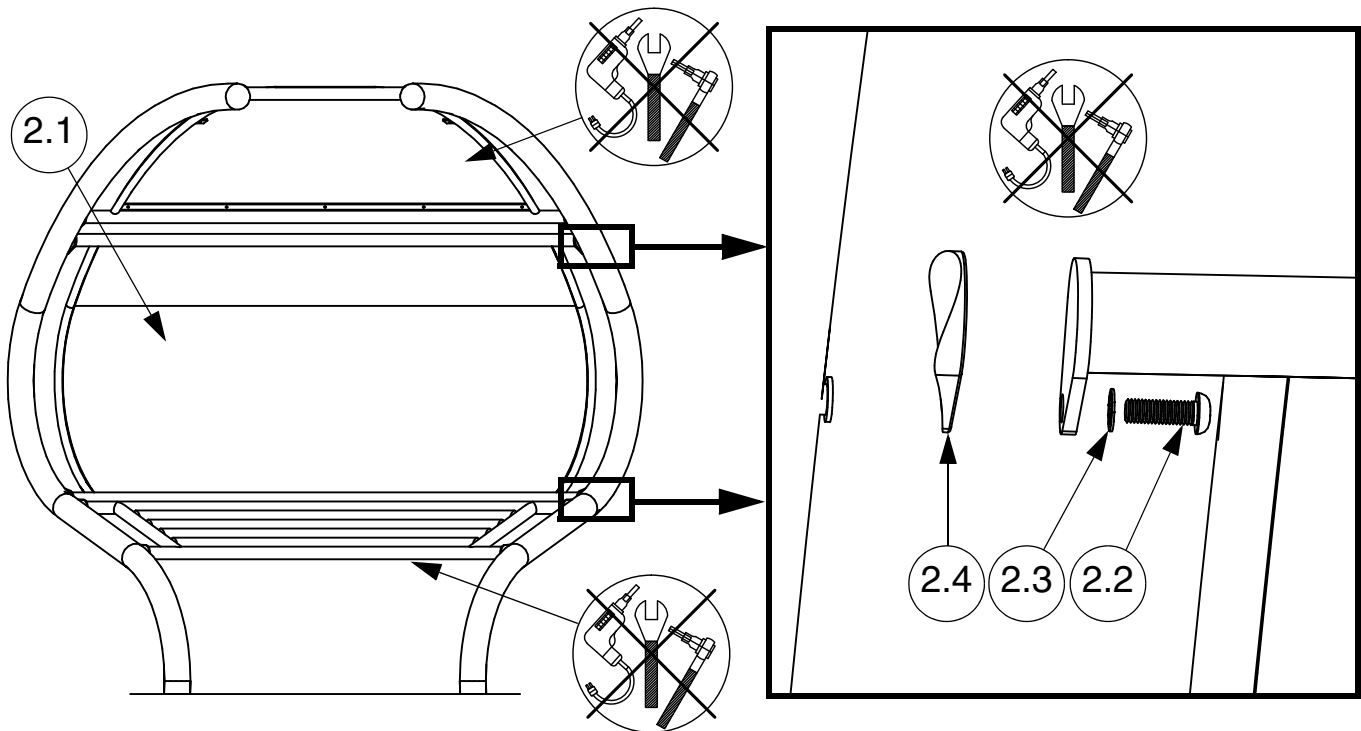

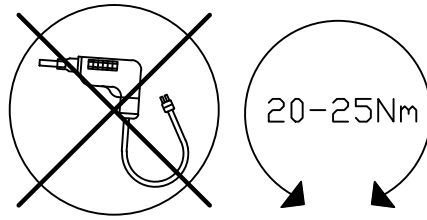
STEP 5

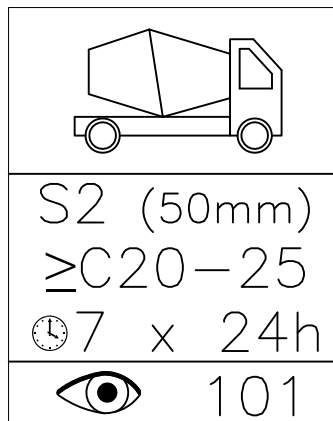
STEP 6

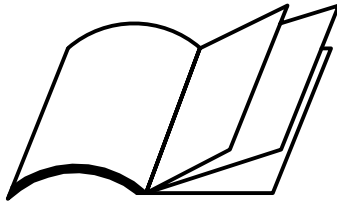

Appendix A: 26000800

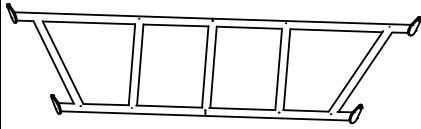
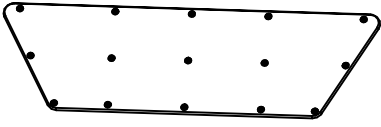
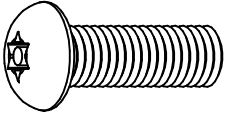
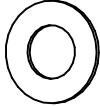
ITEM	REF	26000800	QTY					k.g.
			MPSEATP1	MPSEATP2	MPSEATP3	MPSEATP4	MPSEATP5	
A1	26000801		1	2	3	4	5	6.50
A2	26000803		1	2	3	4	5	3.50
A3	10121030	 M10 X 30	15	30	45	60	75	0.037
A4	10291000	 M10 11X21X1	15	30	45	60	75	0.002

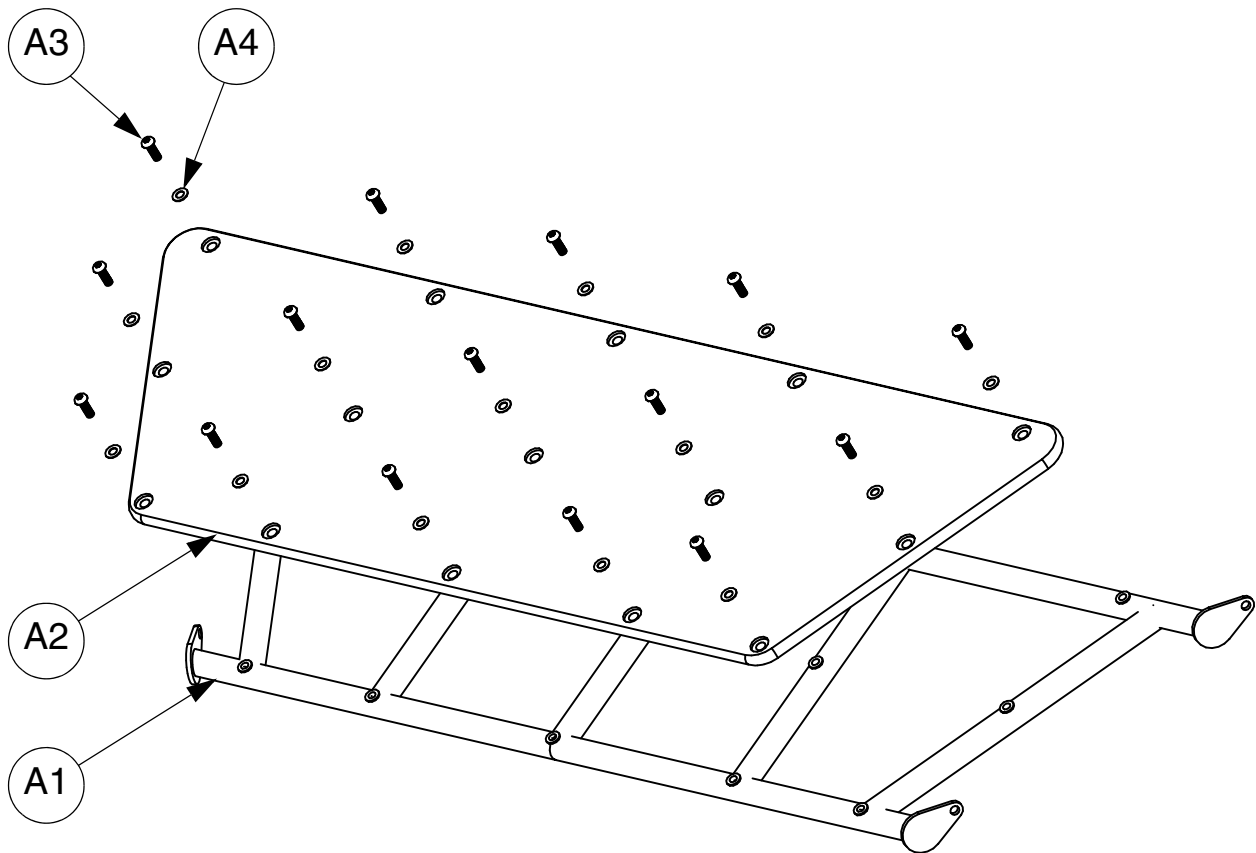

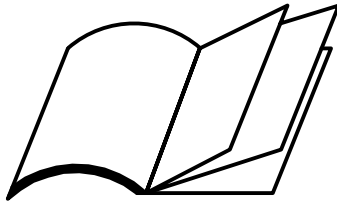

Appendix B: MPSEAT*1D,MPSEAT*2D,MPSEAT*3D,MPSEAT*4D & MPSEAT*5D

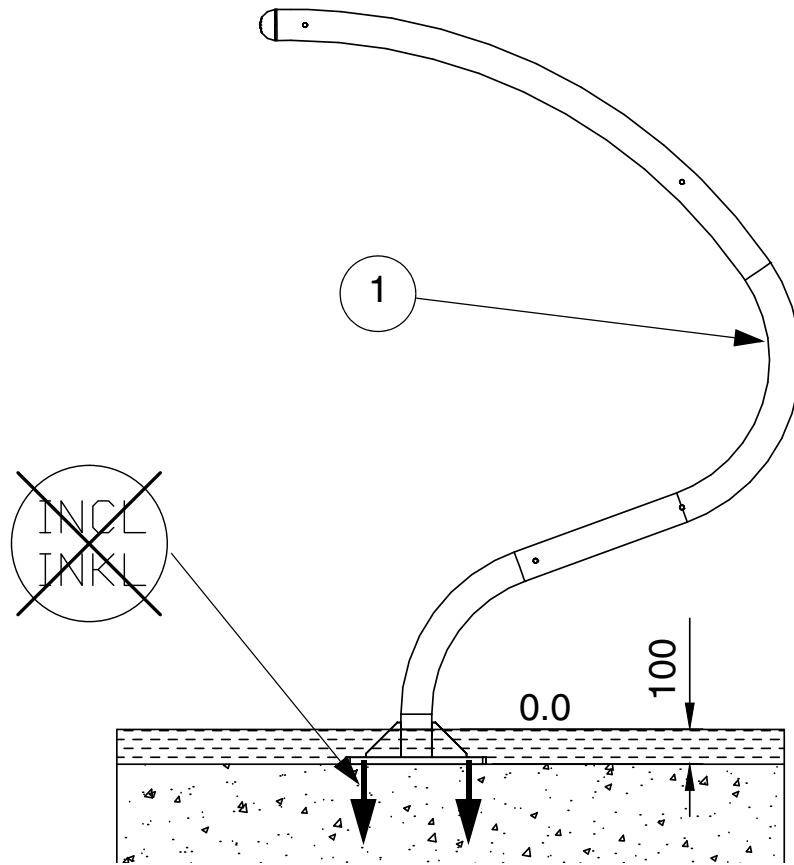

ITEM	REF		QTY								k.g.	
			MPSEATS1D	MPSEATP1D	MPSEATS2D	MPSEATP2D	MPSEATS3D	MPSEATP3D	MPSEATS4D	MPSEATP4D		MPSEATS5D
1	26001101		2	3	4	5	6					54.50

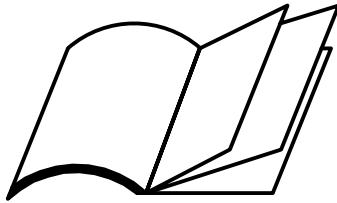

Appendix C:

Constructional Space is the approximate working area required to lay out and assemble the equipment.

For the safe operation of this equipment it must be installed on horizontal ground with the required minimum space.

The concrete foundations indicated are for average ground. Care should be taken concerning abnormal conditions.

1 SAFE WORKING PRACTICE:

A full risk assessment should be carried out prior to commencing the installation, which will be specific to the site selected. The major risks associated with purely the assembly of this product are highlighted below, which can form part of this overall assessment.

RISKS:

- i) Large parts which could be difficult to lift or handle.
- ii) Lifting parts overhead.

CONTROL MEASURES:

- i) Mechanical help to be utilised for any awkward lifting that may be required.
- ii) Ensure Hard hats Gloves, Armoured boots and Protective goggles are worn at all times

Tools: Plumblines, 30m Tape measure, Spirit level, 5/16" AF Driver, M10 Torx tool (Supplied with unit).

Minimum Personal Protective Equipment: Gloves, Armoured boots, Hard hat.

1.1 SURFACING

Refer to suppliers information for selected surface.

Where applicable, refer to site layout drawings for size and shape of base.

2 ASSEMBLY & INSTALLATION ROUTINE

PRE-INSTALLATION INSPECTION.

Inspect all parts for damage (which may have occurred during transportation & storage). Finish coatings, if found to be damaged, should be made good before erection. Any damaged or missing parts must be replaced. To ensure the required hole threads are free from contamination it is recommended that they are brushed out to save time during installation.

- i) Before commencing installation, the surrounding area must be sufficiently fenced and signs erected to warn the public of the risk of injury.
- ii) Making note of the number of seat sections, mark out the outline of the individual footings with spray, chalk etc.

NOTE: If assembling a 1 or 2 seat unit and soil conditions are poor (i.e. clay or loose earth), use the minimum excavation sizes shown, in all other cases the minimum excavation sizes shown in for 3-5 seat unit may be used.

- iii) Excavate holes progressively as the unit is assembled.
- iv) Attach the seat (item 1.2) and spacers (items 1.6) to two posts (items 1.1) using Resistorx bolts (items 1.4) and washers (items 1.5) to the lowest pair of fixing holes in posts.

NOTE: Check the seat has been attached the correct way up. Do not fully tighten .

- v) Attach the roof assembly (item 1.3) and spacers (item 1.6) to the posts (items 1.1) using Resistorx bolts (items 1.4) and washers (items 1.5). Secure to top pair of fixing holes in posts.

NOTE: If MPBACK option is being used, assemble back panel fabrication (item 2.1) and spacers (item 2.4) to posts (items 1.1) using Resistorx bolts (items 2.2) and washers (items 2.3) in same manner as the roof assembly but to central pair of fixing holes in posts.

- vi) Fully tighten all bolts of the assembled section to a maximum of 20 - 25 Nm.
- vii) Place the assembled section into excavations, set to the correct height (chock 100mm of concrete) and support in position.
- viii) Assemble and position the remaining sections progressively.
- ix) When the complete unit is fully assembled, check for square, orientation & height (i.e. Top of seat - 700mm).
- x) Fill the individual footing with concrete to the required level taking into account any surfacing requirements (**Page 3**). Ensure that the full volume of concrete is used. The top of the concrete should slope down and outwards locally from the equipment upstand to the required level to form a watershed.

NOTE: When installing 1 & 2 seat units, the assembly will need to be chocked in its final position (supporting the seat) until the concrete has cured.

- xi) Keep the installation off limits to the public until the concrete has completely cured. (Recommended initial curing time 48hrs).

Concrete mix is recommended at:
 1 part cement;
 2 parts sand;
 4 parts aggregate;
 by volume with 20mm aggregate
 (20 N/mm² min compressive strength)

- xii) In all fixing positions on the steel work that have not been utilised, the protective plug should be removed and the permanent black protective plug (item 1.7) inserted & knocked home with a soft hammer.
- xiii) In surrounding areas where new surfaces have not been laid, make good the existing surface as required.

3 CLEAN SITE AND INSTALLATION INSPECTION

CHECK	CHECK	✓
1 The unit is installed at the correct height.	<input type="checkbox"/>	<input type="checkbox"/>
2 All fixings are tightened to the correct torque and have no protruding sharp edges	<input type="checkbox"/>	<input type="checkbox"/>
3 Paint work is not damaged. (Any making good should be carried out using the procedure in the Inspection and Maintenance instructions).	<input type="checkbox"/>	<input type="checkbox"/>
4 The Eko Grip seat is not damaged. (If applicable)	<input type="checkbox"/>	<input type="checkbox"/>
5 Ensure all unused fixing holes in steel work have correct black protective plug fitted.	<input type="checkbox"/>	<input type="checkbox"/>
6 Concrete foundations and all fixings are in place and secure.	<input type="checkbox"/>	<input type="checkbox"/>
7 Concrete has adequate drainage.	<input type="checkbox"/>	<input type="checkbox"/>
8 Site is clear of tools and rubbish.	<input type="checkbox"/>	<input type="checkbox"/>
9 Remove any warning signs.	<input type="checkbox"/>	<input type="checkbox"/>